

- **Accurate video metrology** – AccuCentric® motorized zoom lens automatically compensates magnification for each zoom position
- **Measurement stability is built-in** – A granite support structure ensures vibration isolation and measurement stability
- **Multisensor versatility** – Optional non-contact sensors and touch probes



Heavy-Duty
Multisensor Measuring System

Axis	Travel (mm)
X axis	450
Y axis	450
Z axis	200
Extend. Y (Opt)	610
Extend. Z (Opt)	300

Machine Weight: 1039 Kg
Crated Weight: 1376 Kg

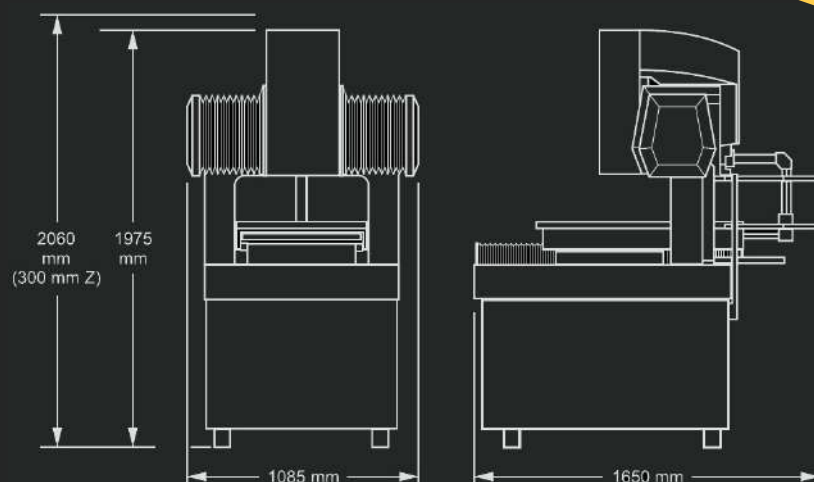



Technical data SmartScope Zip 450

	Standard	Optional
XYZ travel	450 x 450 x 200 mm	Extended Y axis, 610 mm; extended Z axis, 300 mm
XYZ scale resolution	0.1 µm	0.05 µm
Drive system	DC servo with 4-axis control (X,Y,Z, zoom); with multifunction handheld controller	
Worktable	Hardcoat anodized, with fixture holes, removable stage glass, 50 kg recommended max payload	
Rotary axis		Miniature Servo Rotary (MSR), MicroTheta Rotary (MTR), Heavy Duty Rotary (HDR), High Precision Rotary (HPR), Dual Rotary (requires optional 300 mm Z axis)
Optics	AccuCentric® auto-compensating zoom, motorized; 1.0x front replacement lens; 1.0x adapter tube; 2.0x lens attachment	0.5x, 0.75x, 1.5x lens attachments; 1.0x LWD (not for use with SmartRing™ light), 2.5x, 5.0x, 10.0x front replacement lenses; 0.67x, 2.0x adapter tubes; autofocus LED grid projector; laser adapter (includes laser pointer)
FOV size (std optical configuration)	Measured diagonally, 5.0 mm (low mag) to 0.9 mm (high mag)	
Illumination	Substage LED profile (monochromatic), coaxial LED surface (white), SmartRing LED ring light (white)	VuLight™ oblique illuminator, small fiber optic ring light, fiber optic surface light, large fiber optic ring light
Camera	High resolution color digital metrology camera	High resolution black & white digital metrology camera
Image processing	256 level grayscale processing with 10:1 subpixel resolution	
Sensor options (contact OGP for possible combinations of sensors)		Touch probe and change rack, SP25 scanning probe, off-axis DRS™ laser, on-axis TTL laser, Rainbow Probe™ scanning white light sensor, Feather Probe™
Controller	Windows® based, with up-to-date processor and on board networking/communication ports	
Controller accessory package		24" flat panel LCD monitor, or dual 24" flat panel LCD monitors, keyboard, 3-button mouse (or user supplied)
Software	<ul style="list-style-type: none"> Choice of ZONE3 Express or Measure-X or MeasureMind 3D metrology software QVI Portal Portal Navigator Independent Calibration Engine (ICE) Multimedia Content Viewer SmartLink™ 	Metrology software: ZONE3 Express, Prime, or Pro; MeasureMind 3D; Measure-X Productivity software: MeasureFit® Plus, SmartFit® 3D, SmartProfile® Offline software: ZONE3, MeasureMind 3D, Measure-X
Power requirements	100-120 VAC or 200-240 VAC, 50/60 Hz, 1 phase, 700 W	
Rated environment	Temperature 18-22 °C, stable to ±1 °C; 30-80% humidity; vibration <0.001g below 15 Hz	
Operating environment, safe operation	15-30 °C	
XYZ volumetric accuracy	$E_3 = 2.8 + 6L/1000$ µm ^{1,2,4,5}	
XY area accuracy	$E_2 = (1.8 + 4L/1000)$ µm ^{1,2,3,4}	
Z linear accuracy	$E_z = (2.0 + 5L/1000)$ µm ^{1,4} (with 2.0x lens attachment)	$E_z = (1.8 + 5L/1000)$ µm ^{1,4} (with optional TTL laser, or DRS-2000 laser) $E_1 = (1.3 + 5L/1000)$ µm ^{1,4} (with optional DRS-300 or -500 laser, or TP20 or TP200 touch probe)

1Where L = measuring length in mm. Applies to thermally stable system in rated environment. Maximum rate of temperature change: 1 °C/hour. Maximum vertical temperature gradient: 1 °C/meter. All optical accuracy specifications at maximum zoom lens setting. Volumetric accuracy performance requires use of QVI 3D metrology software, such as MeasureMind 3D or ZONE3.

2With evenly distributed load up to 10 kg. Depending on load distribution, accuracy at maximum rated load may be less than standard accuracy.

3Measured in the standard measuring plane. The standard measuring plane is defined as a plane that is within 25 mm of the worktable surface.

4E Z axis linear, E XY area, and E XYZ volumetric accuracy standards are described in QVI Publication Number 790762. 5On-site verification optional.